

Security and Surveillance

INTRODUCTION

Security cameras are seemingly everywhere now especially in recent years. Casinos, public transportation centers, federal and state buildings, commercial office buildings, banks, schools, hotels and other valuable public facilities implement security systems with surveillance cameras.

Traditionally, these cameras record images on inexpensive videotape and each tape stores a few hours of images. It sounds pretty simple until hundreds or even thousands of cameras are involved as they are even in a single casino.

Tapes must be manually changed often or via expensive robotics. Retrieving images for an event can be a time consuming function to find the correct tape, fast forward to an appropriate time and then visually scan the recording. Tapes wear out and mechanical problems are common leading to missed intervals and poor quality recordings. Depending upon the industry, federal regulations often require weeks, months or years of recordings to be available. This means an extremely large number of tapes must be stored and rotated in a complex logistical effort to properly comply.

Finally, when an incident is recorded, there is only one good copy and it is vulnerable to damage or loss. Tape reproductions typically lose quality with each generation and risk wear and damage to the original. Media costs also add up as a large number of tapes are deployed and periodically replaced. It would always have been easier to record this data on disk drives but it was prohibitively expensive – until now.

Enter scalable SATA disk technology from Winchester Systems. With prices for large scale SATA disk farms below

one half cent per megabyte, it is now feasible and economical to deploy disk arrays in the hundreds of terabytes and even in the petabyte range at affordable prices that compete effectively with the overall cost of traditional tape methodology.

WHY REPLACE TAPE WITH DISK

- Low cost and simplicity
- High reliability
- Ease of management
- Reduce hardware costs
- Reduce media costs
- Reduce logistical headaches
- Perfect recordings and copies

REQUIREMENTS

- Cameras
- Networking infrastructure
- SATA data storage

TYPICAL ENVIRONMENTS

- Casinos
- Public highway & transportation facilities
- Federal and state offices
- Banks, hotels, commercial offices
- Schools and colleges

BENEFITS

- Quick installation
- Low cost storage pool
- Efficient capacity utilization
- Easy to manage

See “How is Works” on reverse side

HOW IT WORKS

Video cameras are simply connected to servers running surveillance applications that write image data to disk rather than tape. Of course, the application must be capable of writing to disk and the vast majority of these applications do so today.

The video cameras are connected to the servers via Ethernet architecture. The number and location of cameras dictate the configuration. Typically, a local switch consolidates input from a cluster of cameras and forwards it to the servers via high-speed optical fibre Ethernet as shown in the diagram.

The data is written to the disks in the inexpensive SATA storage pool. Images recorded on SATA arrays are RAID protected and offer high data transfer rates by writing to many disks in parallel. Each SATA array can handle the data stream from a large number of cameras.

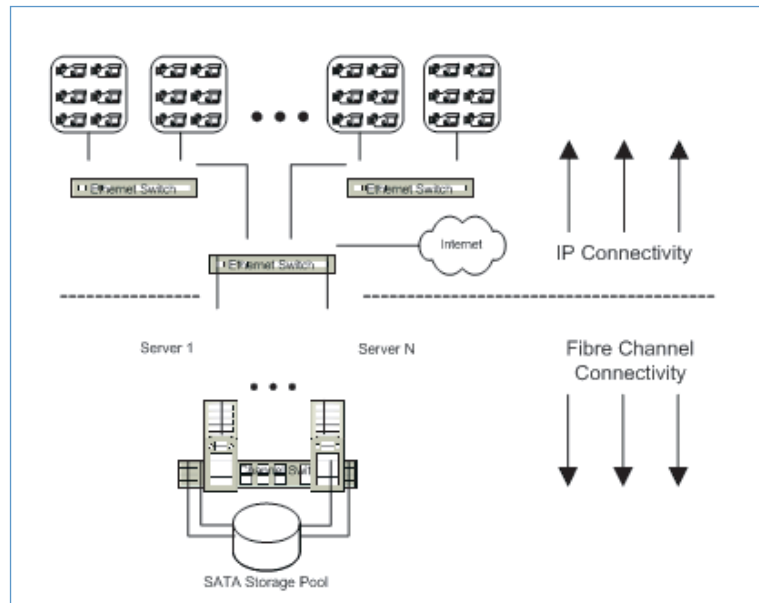

A popular California casino designed this configuration of scalable SATA disk arrays serving hundreds of surveillance cameras over a series of Ethernet connections. This high performance, reliable and easy-to-manage solution can scale to handle thousands of cameras and hundreds of terabytes for large-scale applications at low cost.